

MODEL # U0.25_2012_SLS

PRODUCT FEATURES:

- Arrives on site pre-assembled and function tested
- SCC/CSA field approval ready
- Dual fuel capability, run propane and solution gas without changing orifices
- All applications between 25,000-250,000 BTU/Hr
- Included Patented Kenilworth Combustion burner
- Reduce installation time by 90%
- Fits firetube sizes from 3"-6"
- Ultra low power consumption (solar ready)
- Designed to prevent freeze off from wet fuel gas
- All components mounted in firebox and heat traced

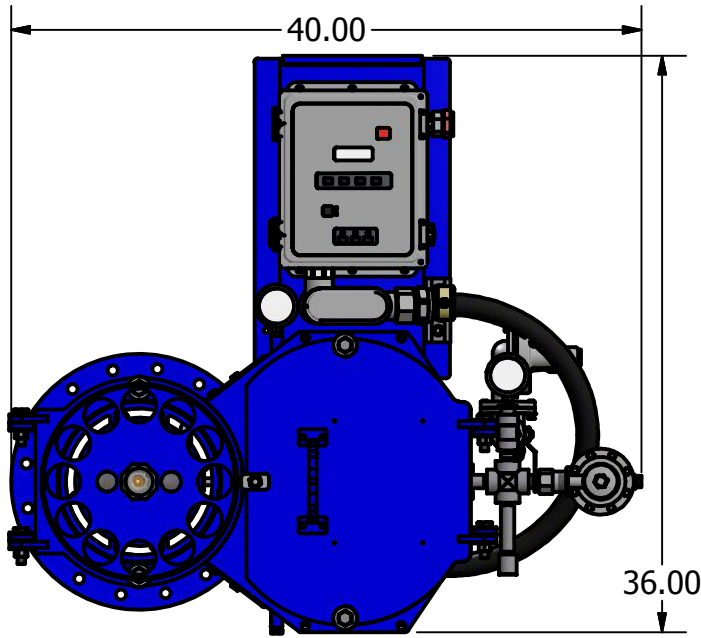
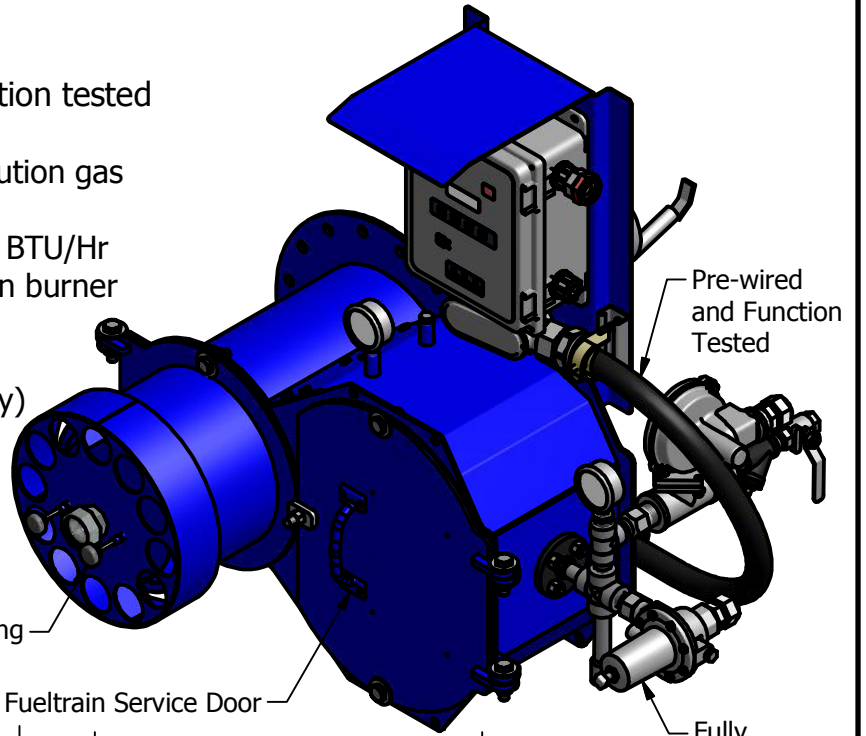

FRONT VIEW

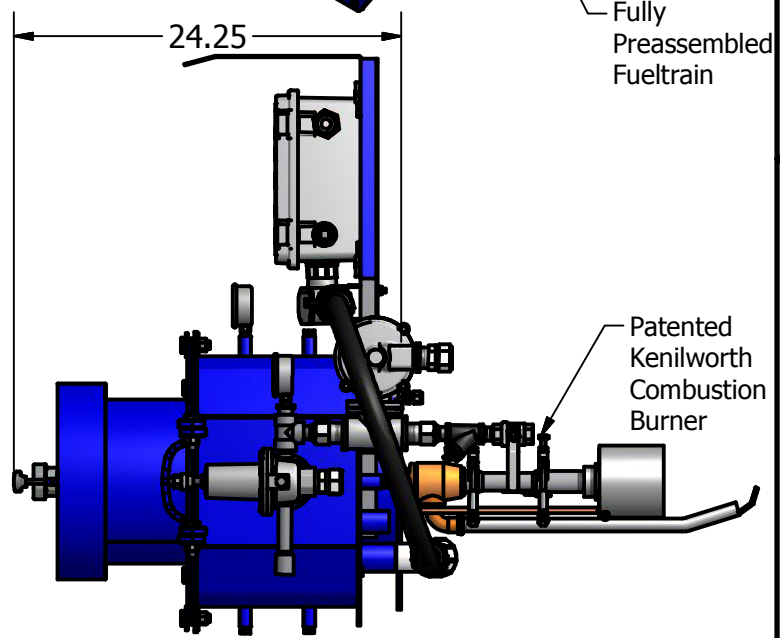

SIDE VIEW

ADDITIONAL OPTIONS

- BMS Choice
- SCC/CSA Field Certification
- Slipstream or Pilot Burner Configuration
- Pre-installed Heat Tracing

KENILWORTH COMBUSTION

MODEL NUMBER

U0.25_2012_SLS

Contact info

www.kenilworth.ca
(780)-853-5340
info@kenilworth.ca

SIZE

A

PRODUCT TYPE

U0.25_2012_SLS

REV

1

SCALE

SHEET 1 OF 2

MODEL # U0.25_2012_SLS

BMS shroud for wall or remote mounting

Multiple choices of BMS

Fully pre-wired and function tested before arriving on site

Standard cable length 15' (other lengths available upon request)

Kenilworth Combustion Flame Scavenger Burner

CSA B149.3 compliant field certifiable fueltrain (internal)

Heat-trace ports

CSA B149.3 compliant field certifiable fueltrain (external)

Terminal block housing for easy and organized wiring

INTERNAL VIEW

ADDITIONAL OPTIONS

- BMS Choice
- SCC/CSA Field Certification
- Slipstream or Pilot Burner Configuration
- Pre-installed Heat Tracing

KENILWORTH COMBUSTION

MODEL NUMBER

U0.25_2012_SLS

Contact info

www.kenilworth.ca
(780)-853-5340
info@kenilworth.ca

SIZE

A

PRODUCT TYPE

U0.25_2012_SLS

REV

1

SCALE

SHEET 2 OF 2